

MACHINING DIMENSION	TOLERANCE		
L (mm)	A	B	C
L≤5	0.10	0.15	0.20
5<L≤15	0.15	0.20	0.25
15<L≤30	0.20	0.25	0.34
30<L≤50	0.25	0.33	0.45
50<L≤70	0.30	0.40	0.55
70<L≤90	0.35	0.48	0.62
90<L≤120	0.40	0.58	0.68
120<L	0.45	0.65	0.75

REV	DESCRIPTION	DATE	CHK. BY	APPROVED

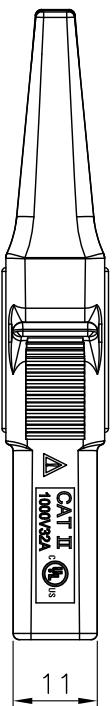

Snap-on P/N	Cabletree P/N	Molding color
2-06433A1	CT001890	Black
2-06433A2	CT001891	Red
2-06433A3	CT001892	Blue
2-06433A4	CT001893	Yellow
2-06433A5	CT001894	Green

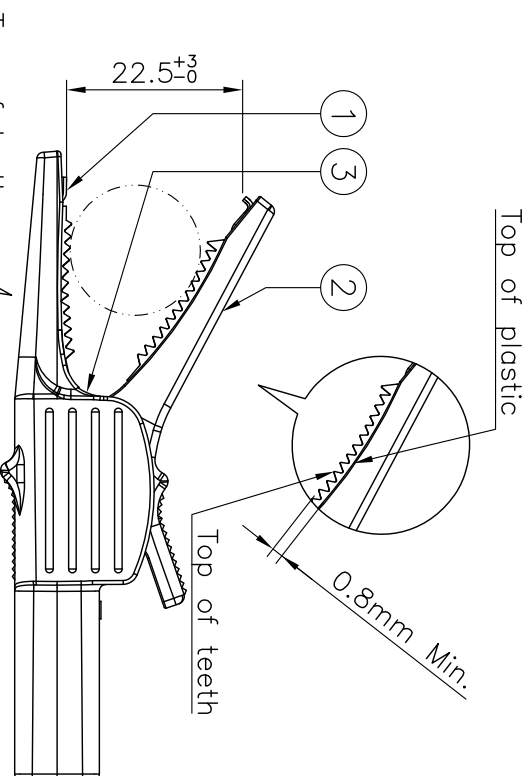
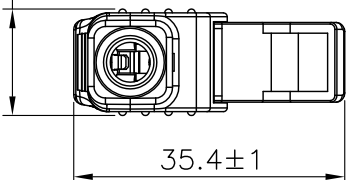
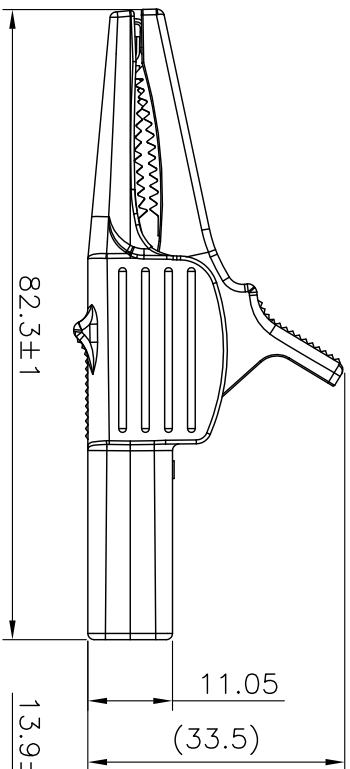
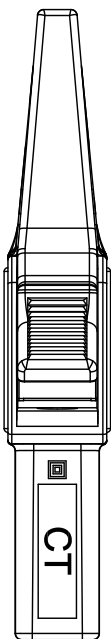

CT Cabletree Industrial Co., Ltd.

NOTES:
 1. Voltage Rating: DC 1000V
 2. Current Rating: 32A

ITEM	DESCRIPTION	VENDOR	MATERIAL	FINISH
03	Spring	Chih Lien	Steel (∅1.35x72C)	Nickel plated
02	Alligator Clip insulation	Nan Ya	PBT (1300ENC1)	Color: (see table)
01	Alligator Clip contact	Tong Horng	Brass (C2680)	Nickel plated

CUST: Snap-on		CUST P/N: 2-06433A1~5	
UNIT SCALE	PERSPECTIVE	TITLE:	Alligator Clip
mm	1:1	CT P/N:	CT001890~4
DWN.BY	CHK. BY	APPROVER	DATE
MARK	PETER	SEP/30/2016	REV SHEET
		A	1 OF 1